









# Chassis Chassis Châssis

Toxic



			
	30-32 mm		
	1045 mm		
HOMOLOGATION	CIK		
	Magnesium		
BODYWORK	Duo/Unico/Stilo		
	Polyester SH		



## Diabolik



	30-32 mm
	1045 mm
HOMOLOGATION	CIK
	Magnesium
BODYWORK	Duo/Unico/Stilo
	Polyester SH





# Magic









	32 mm		
	1045 mm		
HOMOLOGATION CIK			
	Magnesium		
BODYWORK Duo/Unico/Stilo			
	Polyester SH		



## Toledo



	
	30-32 mm
	1045 mm
HOMOLOGATION	CIK
	Magnesium
BODYWORK	Duo/Unico/Stilo
	Polyester SH

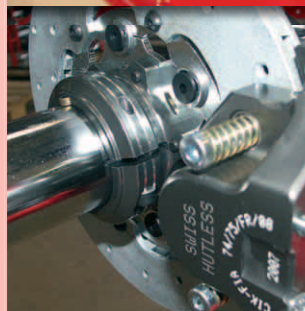



# Vinto









	32 mm
	1045 mm
HOMOLOGATION	CIK
	Magnesium
BODYWORK	Duo/Unico/Stilo
	Polyester SH



## KZ (ICC)



	
	30-32 mm
	1045 mm
HOMOLOGATION	CIK
	Magnesium
BODYWORK	Duo/Unico/Stilo
	Polyester SH

ICC models:/ICC Modelle:/modèles ICC:

**Diabolik**

**Toxic**

**Toledo**

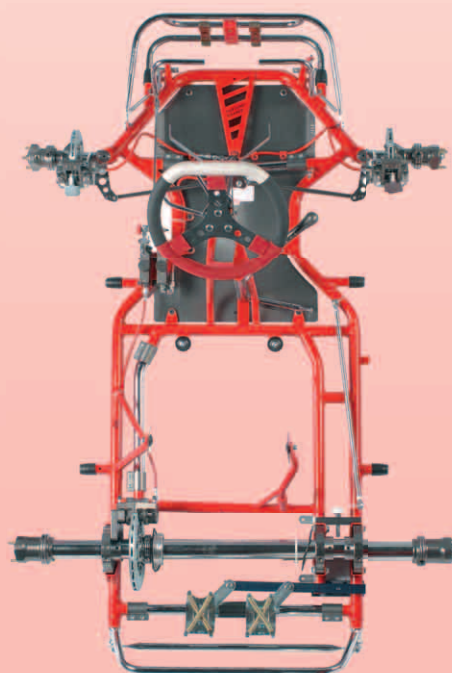

## Inboard Drive

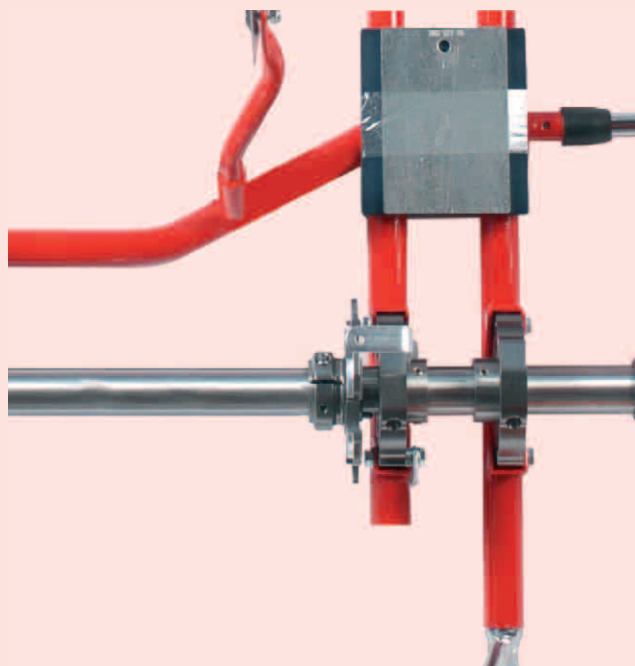

Inboard Drive for:  
 Entraînement Inboard pour:  
 Inboard Antrieb für:

**Diabolik**  
**Toxic**  
**Toledo**  
**Magic**

## SLR Edition

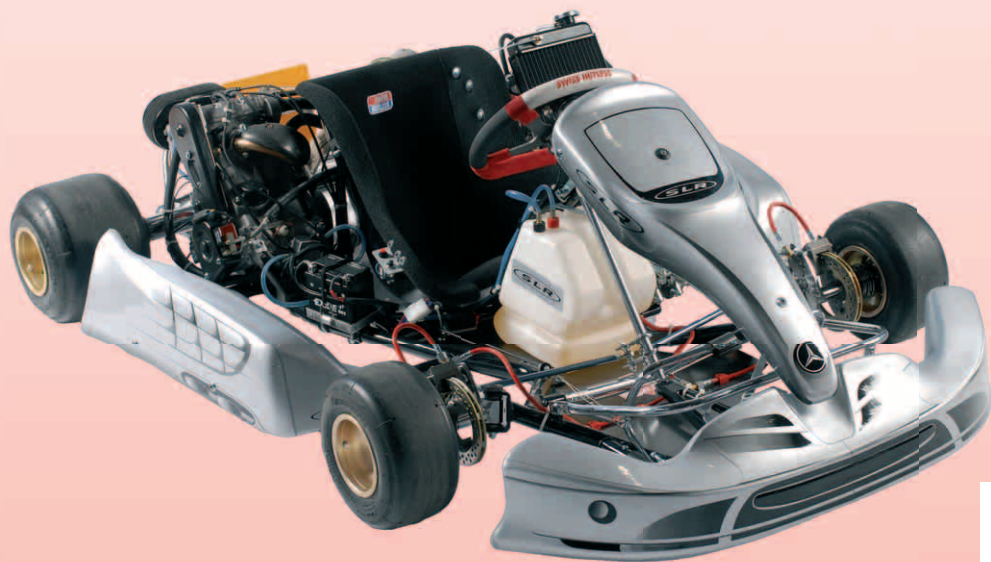

Picture with:/Bild mit:/Photo avec:  
**Biland SA 250 Engine**

	32 mm
	1045 mm
HOMOLOGATION	CIK
	Magnesium
BODYWORK	Duo/Unico/Stilo
	Tillett T7



## DD2



### Rotax FR 125 MAX DD2

#### Engine

2-stroke  
1-cylinder  
24 kW/33 PS  
124,8 ccm  
Liquid-cooled  
Centrifugal clutch  
2-speed gearbox  
Direct drive







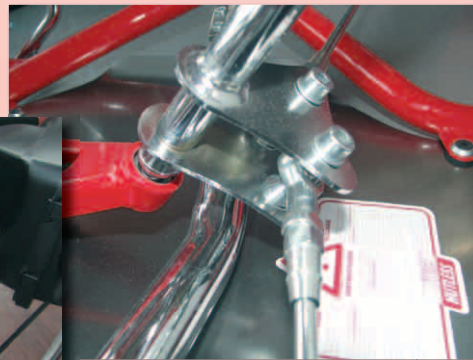
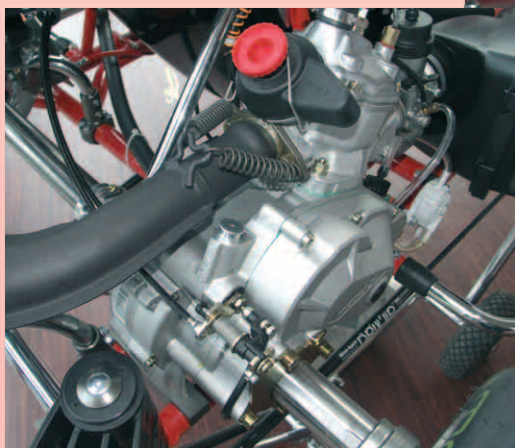

#### Motor

2-Takt  
1-Zylinder  
24 kW/33 PS  
124,8 ccm  
Flüssigkeitsgekühlt  
Fliehkraftkupplung  
2-Gang Schaltgetriebe  
Antrieb direkt auf Hinterachse

#### Moteur

2 temps  
1 cylindre  
24 kW/33 CV  
124,8 cm<sup>3</sup>  
Refroidi par liquide  
Embrayage centrifuge  
Boîte à deux vitesses  
Transmission directe



			
	30-32 mm		
	1045 mm		
HOMOLOGATION	National		
	Aluminium		
BODYWORK	Duo/Unico/Stilo		
	Tillett T7		
	Rotax DD2		







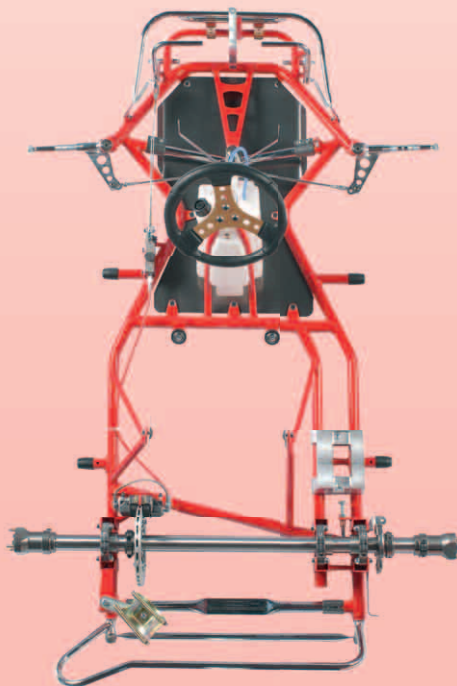
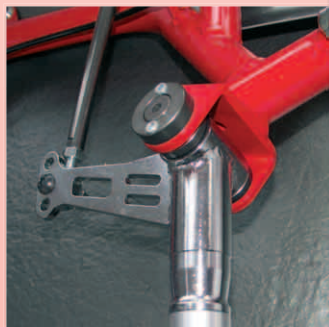



	28 mm
	1045 mm
HOMOLOGATION	National
	Aluminium
BODYWORK	Duo/Unico/Stilo
	Polyester SH



# Fun



	
	32 mm
	1045 mm
HOMOLOGATION	-
	Aluminium
BODYWORK	Duo/Unico/Stilo
	Polyester SH

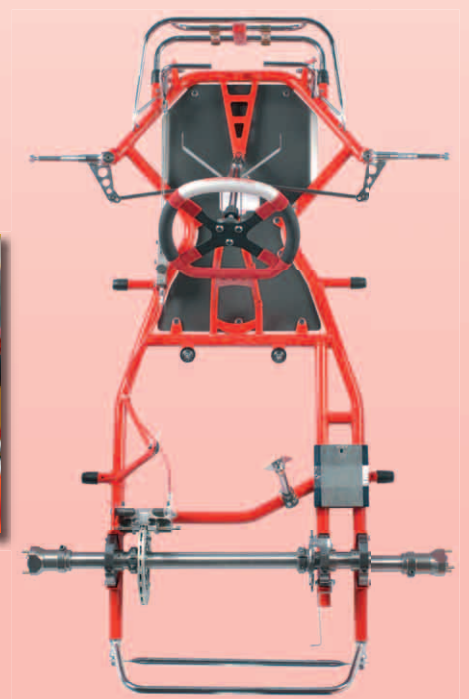



## Mini



### Mini 900/950

	28 mm		
	900/950 mm		
HOMOLOGATION	National		
	Aluminium		
BODYWORK	Mini/Panda		
	Polyester SH		

### Mini 1010

	28 mm		
	1010 mm		
HOMOLOGATION	National		
	Aluminium		
BODYWORK	Panda/Unico		
	Polyester SH		

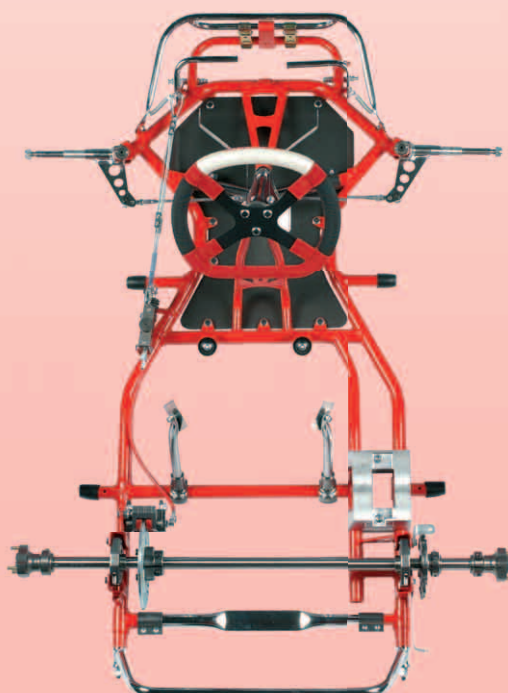

## Rental World Formula



	32 mm		
	1045 mm		
HOMOLOGATION	-		
	Aluminium		
BODYWORK	Unico		
	Polyester SH		
	B&S		

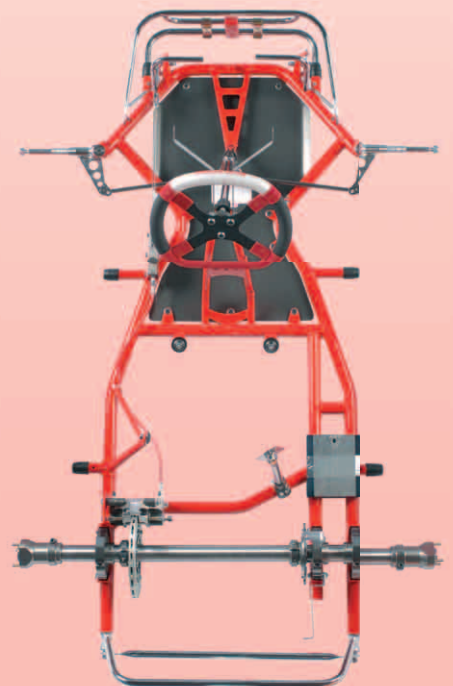
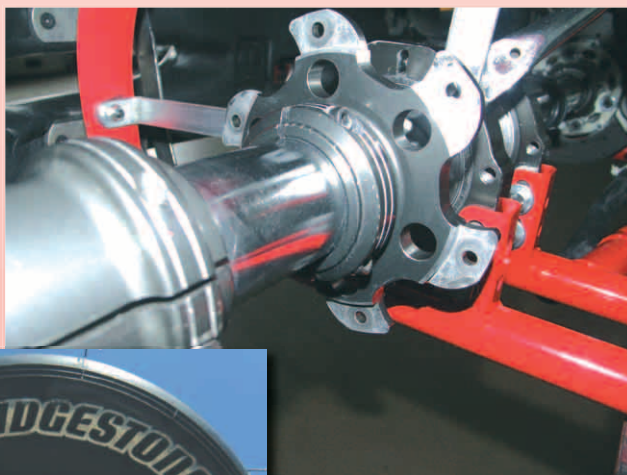





Contact us for more information  
*Kontaktieren Sie uns für mehr Informationen*  
Contactez-nous pour plus d'informations



## *Rental Race Rent*

Contact us for more information  
*Kontaktieren Sie uns für mehr Informationen*  
Contactez-nous pour plus d'informations



## *Rental 200/270*

Contact us for more information  
*Kontaktieren Sie uns für mehr Informationen*  
Contactez-nous pour plus d'informations

